

- ALWAYS mount wheels on **OUTSIDE** of Goal.
- Attach wheel plate by screwing 2 bolts through the 2 round holes on the base.

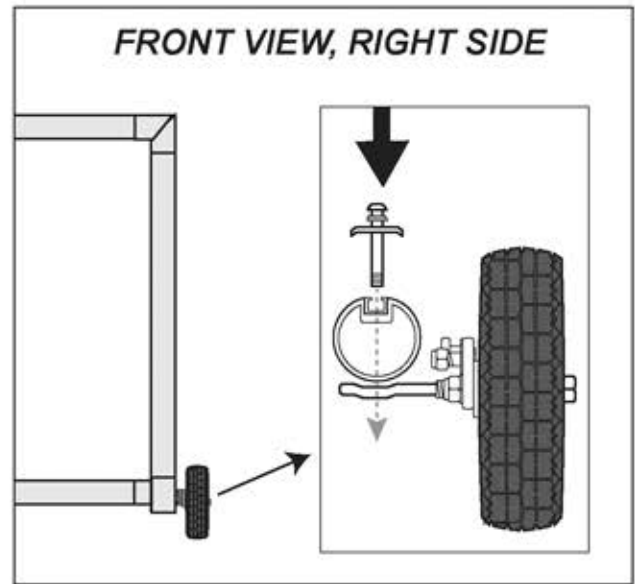

RESTING POSITION - RIGHT SIDE

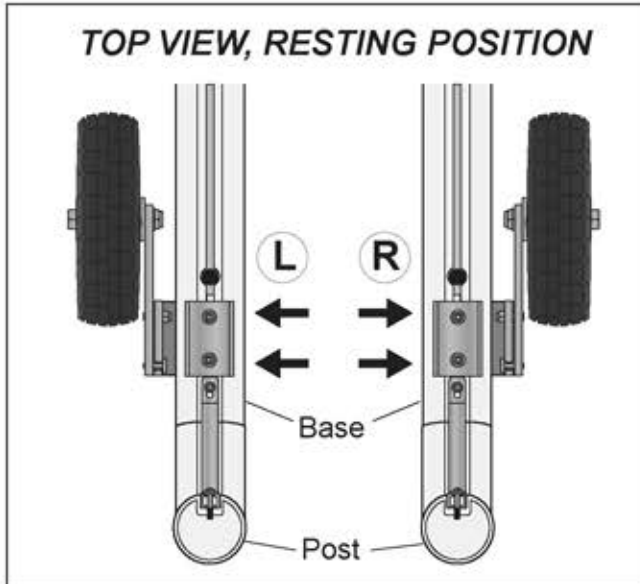
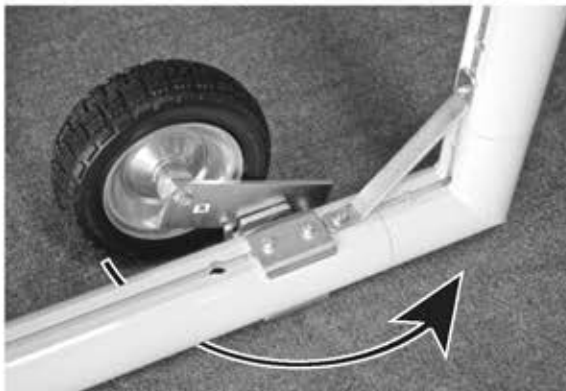

Swivel to set in moving position.

2-WHEEL OPTION

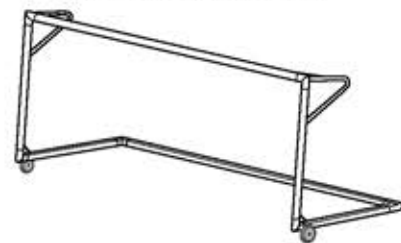

4-WHEEL OPTION



SAFETY INSTRUCTIONS

Check for structural integrity and proper connecting hardware before every use. Replace damage or missing parts or fasteners immediately. Securely anchor or counterweight movable goals at ALL times. Always instruct players, managers, coaches, trainers, teachers, maintenance and all other personnel who might come into contact with the goal on the safe handling of and potential dangers associated with movable soccer goals. Always exercise extreme caution when moving goals and allow adequate manpower to move goal of varied sizes and weights. Movable soccer goals should only be moved by authorized and trained personnel. NEVER allow anyone to climb on the net or goal framework. Movable soccer goals should only be used on LEVEL fields, NEVER on a slope or hill area. Remove nets when goals are not in use. Most of the tipover injuries occurred when goals were unattended. Anchor or chain one goal to another, to itself in a folded down position, or to nearby fence posts, dugouts, or any other similar sturdy fixture when not in use. If this is not practical, store movable soccer goal in a place where children cannot have access to them. Fully disassemble goals for seasonal storage.